

1/2"  $\phi$  HEX BOLT

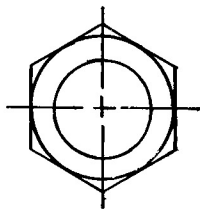

1/2"  $\phi$  HEX NUT

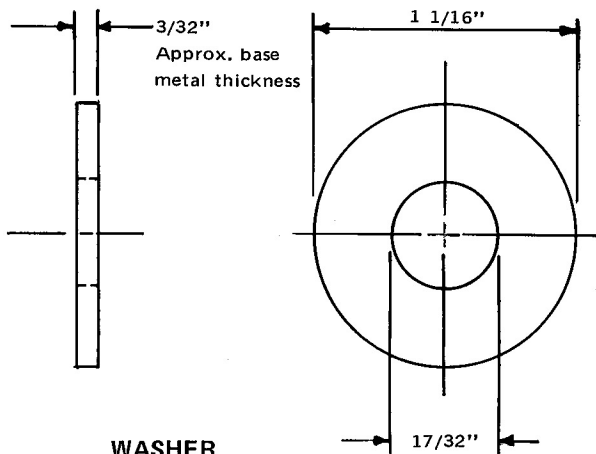
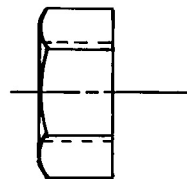

WASHER

### SPECIFICATIONS

Bolts shall conform to the requirements of A.S.T.M. A307 and nuts to the requirements of A.S.T.M. A563, Grade A or better, and be galvanized in accordance with A.S.T.M. A153 except when corrosion resistant steel bolts are requested in which case bolts and nuts shall be made of steel having an atmospheric corrosion resistance approximately two times that of carbon structural steel with copper and shall not be galvanized. Corrosion resistant bolts and nuts shall conform to or exceed the mechanical requirements of A.S.T.M. A307 and A563, Grade A, respectively.

Bolts and nuts shall be of the hex or heavy hex types.

Washers shall be made of steel and shall be galvanized in accordance with the requirements of A.S.T.M. A153 except when corrosion resistant steel is required in which case the washers shall be made of steel having an atmospheric corrosion resistance approximately two times that of carbon structural steel with copper and shall not be galvanized. They shall meet the dimensional requirements of A.N.S.I. B27.2, Type A Plain Washer. No punching, drilling, or cutting will be permitted after galvanizing.

### INTENDED USE

This bolt is for fastening rail support angles to posts in the standard Box Beam Guardrail system G3 .

1/2" HEX BOLT  
AND NUT AND WASHER

HM-TF-13

STANDARD

F-6 -76